

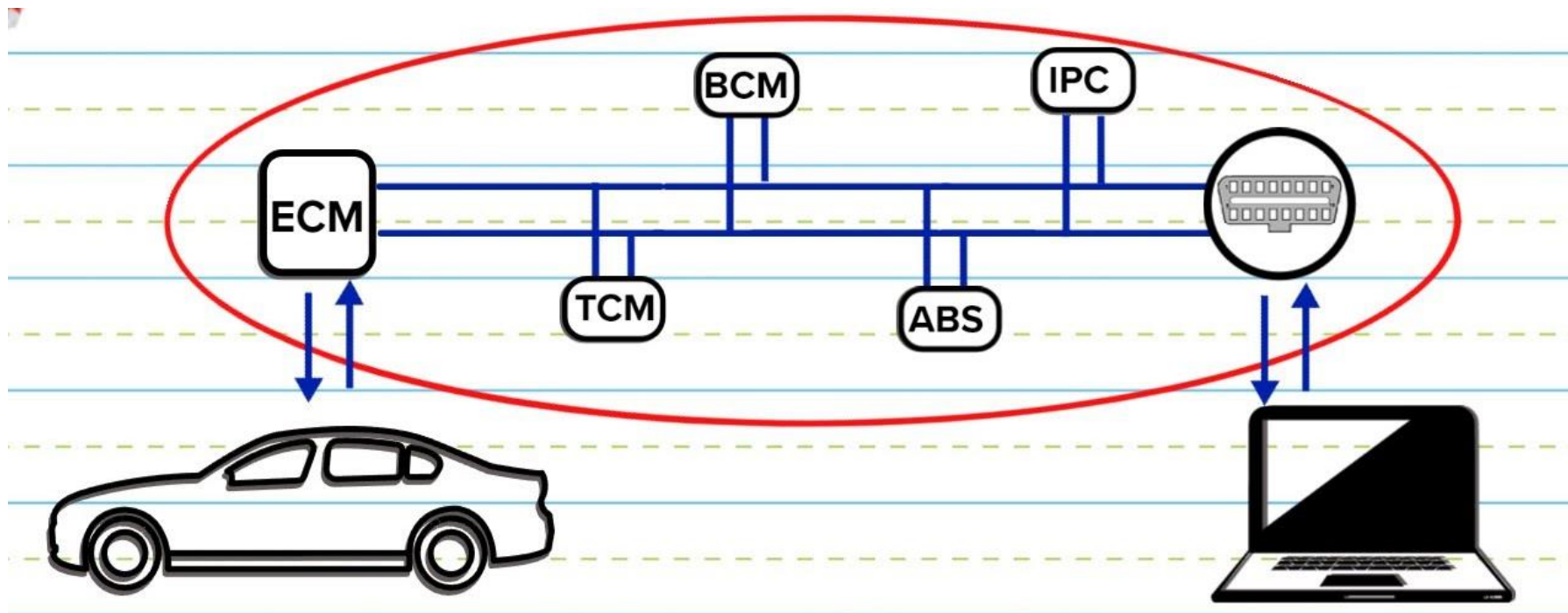

Fundamentals of Industrial Measurement Technology

CAN Communication



ProDSP Post Series Nr.39.



The CAN bus is an **extremely robust** and **noise-tolerant** communication protocol, but only if the basic physical constraints are respected.





At **short distances and lower speeds** (~500 kbaud), communication often **works even** with **non-standard wiring**, however, this is **not** an **acceptable** solution **in industrial** test equipment.





When working with **longer cabling** (20–30 m) or in **noisy environments** (motors, high-current DC-DC converters), **standard CAN wiring is essential.**





Elements of optimal CAN wiring

- CAN High / CAN Low on a twisted pair
- Reference ground
- Shielded cable, grounded on one side
- 120 Ω termination on both ends (not optional!)





It is important to clarify whether the **DUT includes termination**, if not, it must be provided with an **external resistor close** to the connector.





General CAN D-SUB pinout

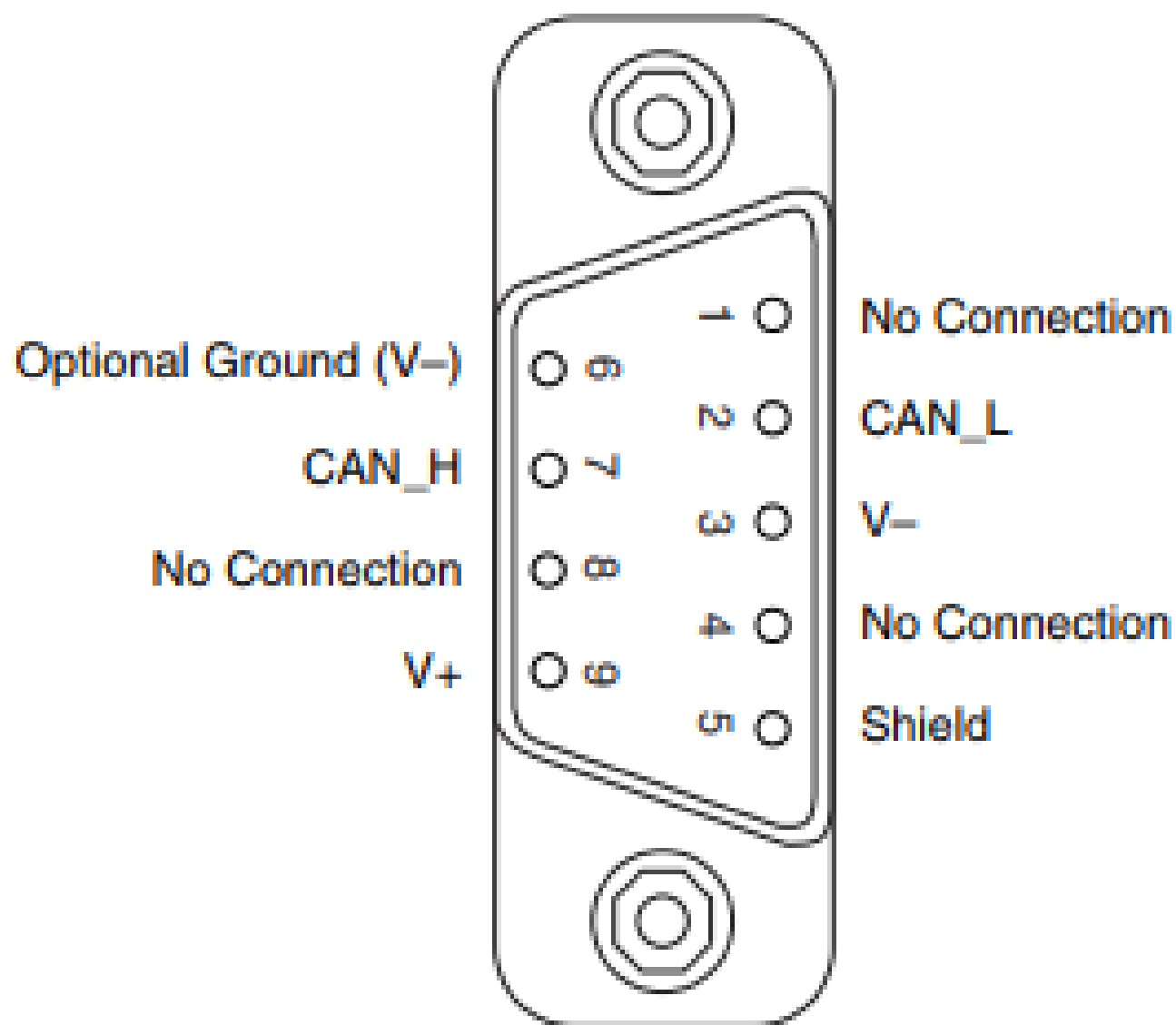



Optimal wiring according to the standard

Wire Layout

(Example)

Single shielded double twisted pair cable (four-wire cable, 2x 2x 0.22mm²)

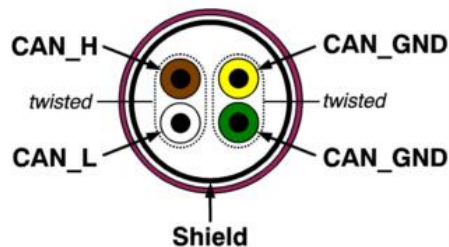

Signal assignment of single shielded double twisted pair cable with earth and termination

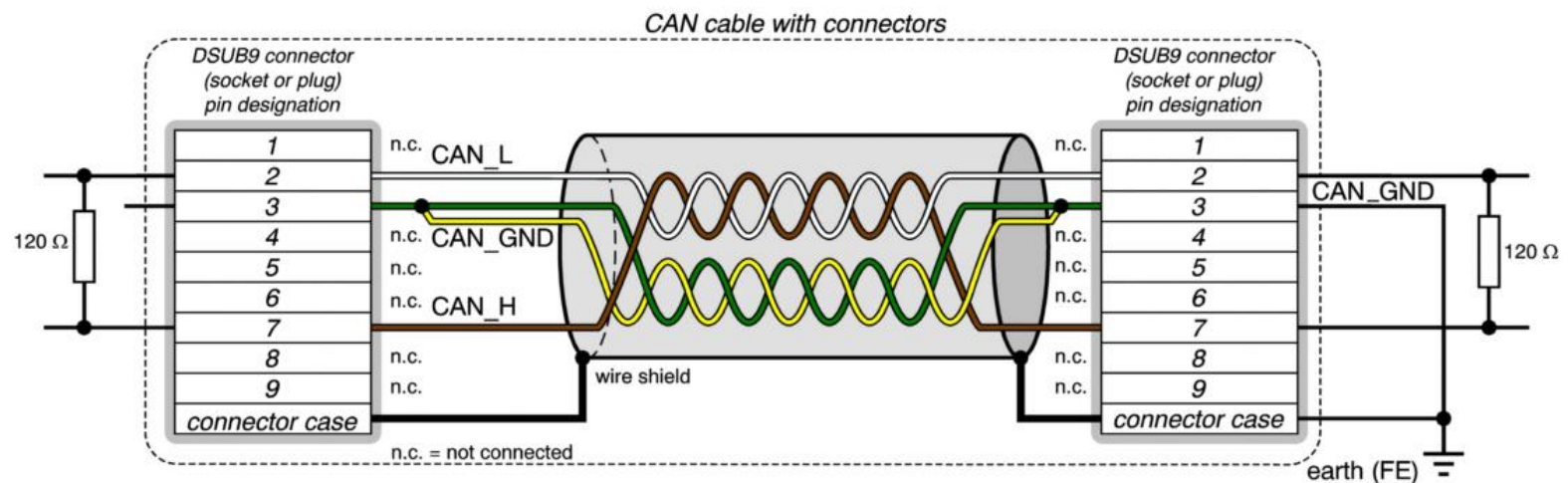



Simplified CAN wiring diagram

Wire Layout

Single shielded twisted pair cable (two-wire cable, 1x 2x 0.22mm²)

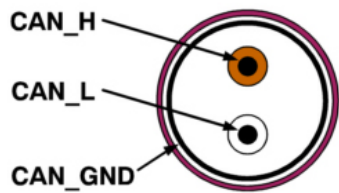

Signal assignment of single shielded twisted pair cable with earth and termination

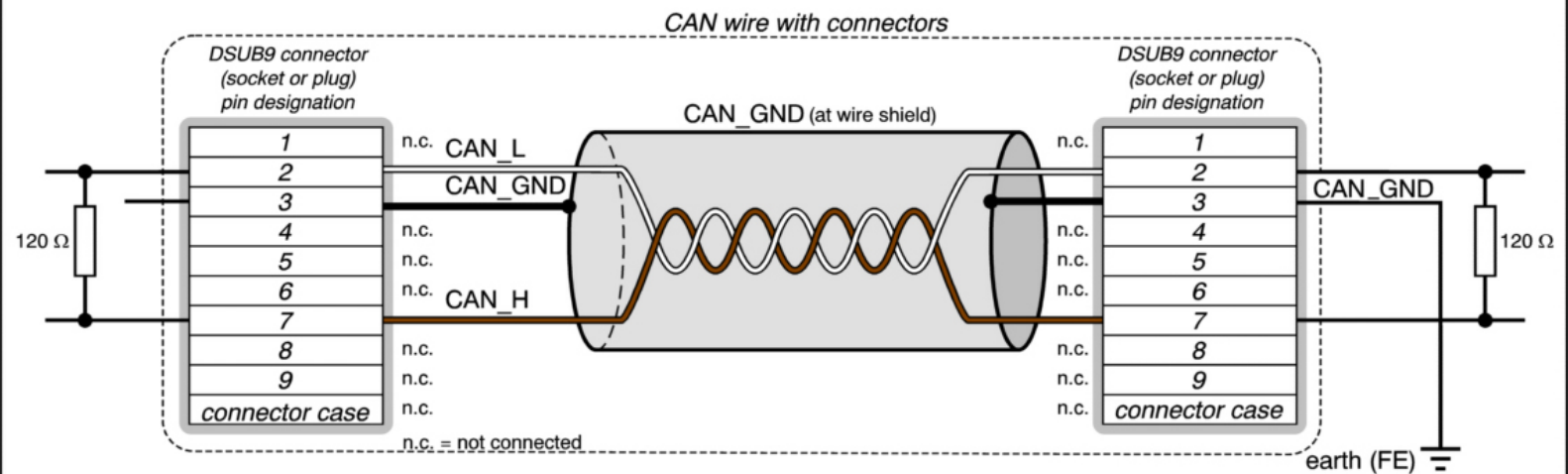



Recommended CAN bus topology and maximum distances

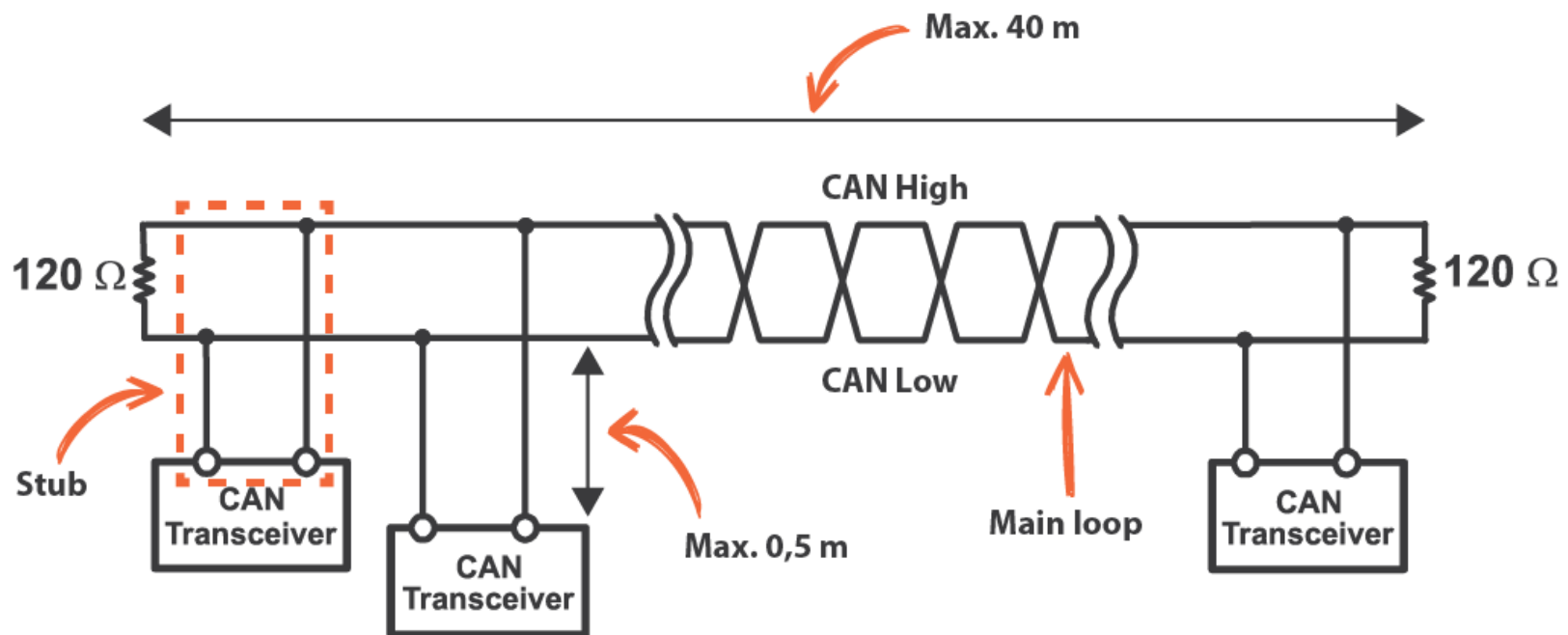



Follow us for more!

